

Installation and Operating Manual

SEN 40 / SAN 40 NTP Movement

Please read these instructions carefully before installation.



Product Certification

STANDARDS

The NTP movement SEN 40 was developed and produced in accordance with the EU Guidelines:

2006 / 95 / EC
2004 / 108 / EC
96 / 48 / EC



References to the Instruction Manual

1. The information in this Instruction Manual can be changed at any time without notice. The current version is available for download at www.mobatime.com.
2. This Instruction Manual has been composed with the utmost care, in order to explain all details in respect of the operation of the product. Please do not hesitate to contact us if you have any questions. Thank you for reporting any possible mistakes.
3. We do not answer for direct or indirect damages which could occur when using this manual.
4. Read the instructions carefully. Only start setting-up the product if you have understood the information for installation and operation.
5. The installation must only be carried out by skilled staff.
6. It is prohibited to copy this publication or to store it on a computer system. All rights reserved. Copyright © BÜRK MOBATIME GmbH D-78026 VS-Schwenningen / GERMANY and MOSER-BAER AG CH 3454 Sumiswald / SWITZERLAND.

Guidelines for installation and handling



1. The movement may only be transported in the original packing and must be stored in a dry environment.

Content

1. Measurements, definitions	4
2. Function description	5
3. Mounting guidelines	6
3.1 Mounting of movement SEN/SAN 40	6
3.2 Mounting of hands and starting-up	6
3.2.1 Mounting of hands	6
3.2.2 Starting-up and check of the hand positions	6
3.2.3 Maintenance	6
4. Configuration	7
4.1 Overview	7
4.2 Switches	7
4.2.1 Reset	8
4.3 Operation modes	9
4.3.1 Unicast	9
4.3.2 Multicast	10
4.3.3 Slave movement (cascading)	12
5. Operation details	12
5.1 Power supply	12
5.2 DHCP	12
5.3 IPv6	13
5.4 DHCPv6	13
5.5 Autokonfiguration / SLAAC	13
5.6 SNMP	13
5.7 Local time calculation	13
5.8 Accuracy / synchronization loss	14
5.9 Time source redundancy	14
5.9.1 Unicast	14
5.9.2 Multicast	14
5.10 MOBA-NMS (MOBATime Network Management System)	14
6. Update	15
6.1 Bootloader update	16
7. Connectors	17
8. Technical specifications	17
9. Time Zone Table	18
10. Accessories	20

1. Measurements, definitions

Models:

- SEN 40 (with second) Art. No.: 204017
- SAN 40 (without second) Art. No.: 204018

Notice: This document describes all functions for all models. Descriptions of the second hand are valid for the model SEN 40 only.

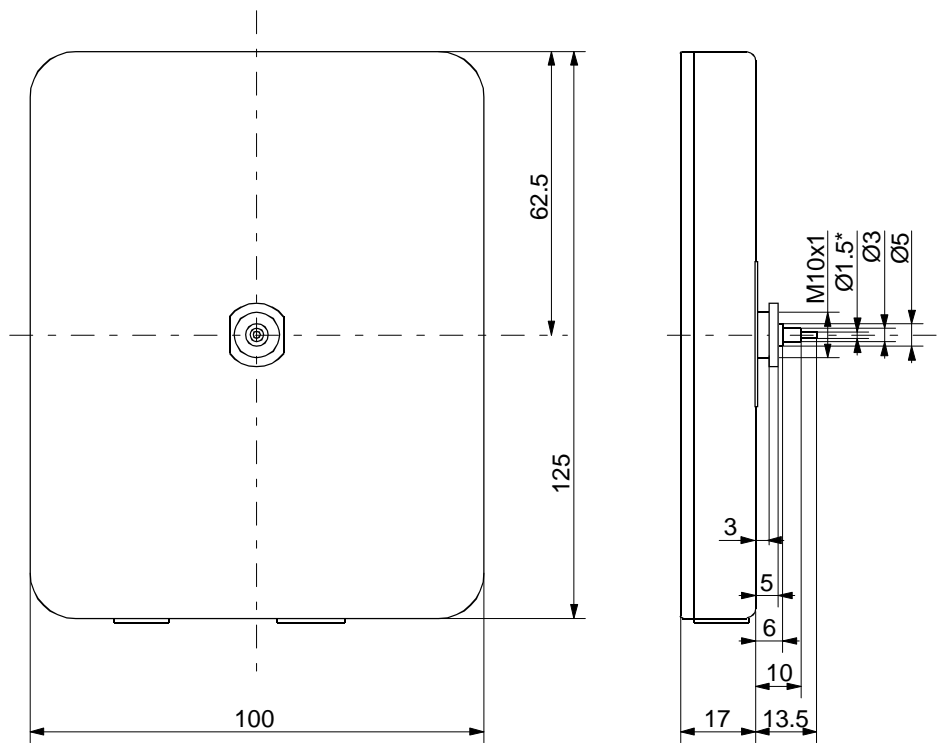

*for SEN 40 only

2. Function description

The SEN 40 is a self-setting movement with hour, minute and second display. The movement is network capable and can be synchronized by NTP (Network Time Protocol). It is suitable for indoor and outdoor clocks with dial diameters up to 400 mm.

Features:

- 10/100 Mbit/s Ethernet LAN connection.
- Power supply PoE (Power over Ethernet).
- Synchronization by a NTP server in the network.
- Cascade of a slave movements (I²C bus). Synchronization, power supply and supervision by the master movement. For double sided clocks only one LAN connection is required.
- Operation mode selectable by means of 12 DIP switches.
- Automatic takeover of the network configuration:
 - IPv4: from a DHCP server in the network: IP address, gateway address, subnet mask, up to 4 NTP server addresses, time zone server address, SNMP manager address.
 - IPv6: -SLAAC: IP address
-DHCPv6 server in the network: IP address, up to 4 NTP server addresses, time zone server address, SNMP manager address

Alternatively: the network configuration can be set manually using the PC tool MOBA-NMS.

Alternatively use of a multicast IP address for synchronization / communication. Address selectable by means of DIP switches for minimum configuration effort.

- Automatic daylight saving time change according to a predefined daylight saving time rule (1 out of 7 rules selectable by means of DIP switches). The rules can be programmed by means of the PC tool MOBA-NMS.
Alternatively automatic daylight saving time change according to a daylight saving time rule provided by a MOBATime time zone server in the network. (1 out of 7 rules selectable by means of DIP switches).
- Integration of the movement to a network management system (SNMP manager) supported. Master movements can send out SNMP V1 alarm traps and periodic alive traps for supervision.
- Signalization of missing NTP synchronization after 24 hours by setting the hands to the 12:00 position.
- Different running modes (stepwise or continuous) of the minute and second hand selectable by means of DIP-switches.

3. Mounting guidelines

3.1 Mounting of movement SEN/SAN 40

The dial must be sufficiently stable. The fixing hole must have a diameter of 10.3 mm. The movement must be fixed in vertical position.

Ill. 1 shows the positions of the mounting parts.

The disc nut (5) M10 x 1 has to be tightened carefully with a special wrench tool (Art. No.: 204331) and a torque wrench with a torque of (4.5 +/- 0.2) Nm.

Caution:

After tightening the disc nut (5), the movement must not be wrenched!

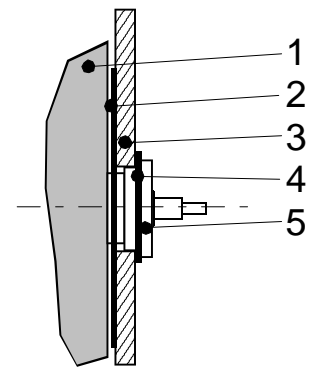

Illustration 1

- 1 Movement
- 2 Rubber washer
- 3 Dial
- 4 Metal ring (optional)
- 5 Ring nut

3.2 Mounting of hands and starting-up

3.2.1 Mounting of hands

The shafts of the hour, minute and second hands are positioned ex-work on the reference position (12 o'clock). Insert the metal needles into the holes on the back side (ca. 6-7mm deep, ill. 2). Mount the hands and move them to the 12:00 position. Enough space must be provided between the hands and the movement must rest on a stable surface (see ill. 3). After mounting the hands, remove the needles.



Illustration 2

3.2.2 Starting-up and check of the hand positions

- DIP switch 1.1 to ON position (12:00 position, refer to chapter 4.2).
- Connect to PoE (Power over Ethernet). The clock runs to the 12:00 position.
 - ➔ Are the hands exactly positioned at 12:00 position?
- If the hand positions are wrong: insert metal needles into the two holes on the back side (ca. 6-7mm deep, ill. 2), adjust the hands and remove the needles.
 - ➔ Check the 12:00 position again (initialize procedure by disconnecting PoE).
- If the hand position is OK, continue with chapter 4 for further configuration.

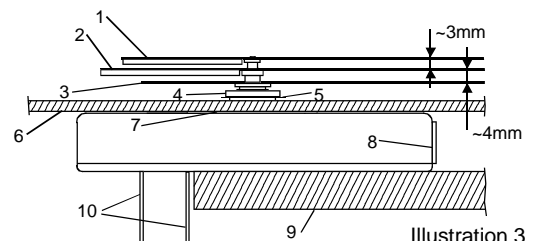

Illustration 3

- 1 Second hand
- 2 Minute hand
- 3 Hour hand
- 4 Ring nut
- 5 Metal ring (optional)
- 6 Dial
- 7 Rubber washer
- 8 LAN (PoE) input
- 9 Rest
- 10 Metal needles

3.2.3 Maintenance

If the hand positions need to be checked, repeat the steps in 3.2.2.

4. Configuration

4.1 Overview

The NTP movement SEN 40 has three different operation modes:

- **Unicast**

The movement works as NTP client and I²C master. It has an own IP address. See chapter 4.3.1.

- **Multicast**

The movement works as NTP client and I²C master. It joins a group address (multicast IP address). See chapter 4.3.2.

- **I²C-Slave**

The movement is connected to the I²C bus and is controlled by a master movement. The slave has no network connection. See chapter 4.3.3.

Configuration takes place via two DIP switch groups located on the housing side of the movement (see chapter 4.2). The network configuration is automatically done by:

-IPv4: DHCP server (see chapter 5.2)

-IPv6: SLAAC or DHCPv6 Server (see chapter 5.3 and 5.5)



-manually using the PC tool MOBA-NMS (see chapter 5.10)

4.2 Switches

The movement has 12 DIP switches.

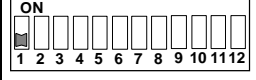
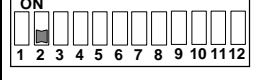
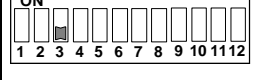
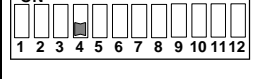

The following settings are possible:

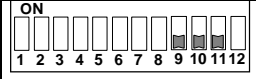
Switch:	Position OFF:	Position ON:
1	 Movement runs on time (if synchronized)	Movement runs to 12:00 position
2	 Second hand in stepwise mode	Second hand in continuous mode
3	 Minute hand in stepwise mode	Minute hand in continuous mode
4	 Use daylight saving time rule from internal time zone table (selection 0..7 with switches 9 to 11)	Daylight saving time rule provided by time zone server (selection of rule 1..7 with switches 9 to 11)
5 - 8	 The movement operates with a unicast address: 5: 0 6: 0 7: 0 8: 0	Multicast address (binary value): 5: 1 6: 2 7: 4 8: 8
9 - 11	 Time zone (binary value): 9: 0 10: 0 11: 0	Time zone (binary value): 9: 1 10: 2 11: 4

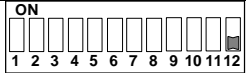
12		Multicast address range 239.192.54.1-15 resp. FF38::EFC0:3601-360F (selection 1..15 resp. 0x1-0xF with switches 1.5 to 1.8)	Multicast address range 239.251.34.1-15 resp. FF38::EFCB:2201-220F (selection 1..15 resp. 0x1-0xF with switches 1.5 to 1.8)
----	---	--	--

4.2.1 Reset

Most changes of the configuration switches cause the movement to restart (software reset). It is therefore recommended to set the switches correctly prior to applying power.

Switches 1 and 9 to 11 do not trigger a reset. All other switch changes lead to a restart (depending on the selected operation mode the movement needs to re-initialize).

If during operation all switches are set to ON position for 10 seconds, the movement executes a factory reset. All configuration settings will be reset to default values.



Switches:

Default values:

Description (20 chars)	NTP Movement SEN 40
IP mode	IPv4 and IPv6 on
DHCP IPv4	on
IPv4 IP address	1.255.255.253
IPv4 subnet mask	255.255.255.0
IPv4 gateway address	1.255.255.252
IPv6 fix address/prefix	0::0/64
IPv6 link local address	see calculation in chapter 5.3
DHCPv6	on
IPv6 autoconfiguration (RA, SLAAC)	on
Host name	MOBATIMExxxxxx, with the last 6 digits corresponding to the last 6 digits of the MAC address. e.g. MAC 00:16:91:12:34:56 → MOBATIME123456
NTP server address 1	0.0.0.0
NTP server address 2	0.0.0.0
NTP server address 3	0.0.0.0
NTP server address 4	0.0.0.0
NTP request interval [s] (10...99)	10
Time zone entry 1	London
Time zone entry 2	Brussels
Time zone entry 3	Athens
Time zone entry 4	Bucharest

Time zone entry 5	Cairo
Time zone entry 6	Amman
Time zone entry 7	UTC
Configuration port number	65532
Time zone client port number	65534
DHCP support on/off	on
SNMP manager address 1	0.0.0.0 / 0::0
SNMP manager address 2	0.0.0.0 / 0::0
SNMP alive trap interval [min] (1...1440)	30

Additionally the SEN 40 can be reset by means of the PC tool MOBA-NMS.

4.3 Operation modes

4.3.1 Unicast

The movement has a network connection and is synchronized to UTC (Universal Time Coordinated) from a NTP server. It is able to synchronize, power and supervise a cascaded slave movement (SEN 40) on the I²C bus.

This operating mode supports the monitoring and configuration of the movement via the network connection. Network parameters can be automatically obtained from a DHCP server or can be manually configured by means of the PC tool MOBA-NMS.

For supervision and configuration with MOBA-NMS one of the group addresses (multicast IP addresses) 239.192.54.0 or 239.251.34.0 for IPv4 resp. FF38::EFC0:3600 or FF38::EFFB:2200 for IPv6 or the IP address is used (selection with switch 12).

It is possible to connect an *I²C monitor* to the cascade. The movement writes periodically time, configuration and status information to the display. Monitoring can help to find network configuration errors.

If the movement is powered by PoE and the switches 5 to 8 are in OFF position the Unicast mode is selected.

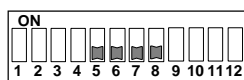

Switches:

In this operating mode the movement will attempt to obtain the following network parameters from a DHCP server (see chapter 5.2):

- IP address
- Gateway address
- Subnet mask
- NTP server address(es) / Time zone server address
- SNMP manager address

In this operating mode, the clock will try to obtain the following network parameters in an IPv6 network from a DHCPv6 server (see also chapter 7.4):

- IP address
- NTP server address(es) / time zone server address
- SNMP manager address

The NTP server addresses must be configured by the network administrator as DHCP options on the DHCP server. If a NTP server address was provided to the movement it will request time and time zone packets (switch 4 in ON position) from this server. The request interval can be configured with the PC tool MOBA-NMS.

4.3.2 Multicast

The movement has a network connection and is synchronized to UTC (Universal Time Coordinated) from a NTP server. It is able to synchronize, power and supervise a cascaded slave movement (SEN 40) on the I²C bus.

Configuration can completely be done by means of the DIP switches on the movement (minimal configuration effort). Further this mode supports monitoring of the movement via the network connection. Single configuration parameters can be changed with MOBA-NMS via network.

For monitoring and configuration with MOBA-NMS, one of the multicast group addresses (multicast IP) is used. The group address is an IP address in the multicast range (224.0.0.0 to 239.255.255.255), addresses selected by Moser-Baer AG from a freely available range:

-IPv4: 239.192.54.x and 239.251.34.x, whereat x = 1..15

With IPv6, the ranges mentioned above are implemented as follows:

-IPv6: FF3y::EFC0:360x and FF3y::EFC0:360x, whereat x = 0x1..0xF and y=scope

E.g.: 239.192.54.5 → FF38::EFC0:3605 or 239.251.34.10 → FF38::EFC0:360A

















For scope, the following values are possible:











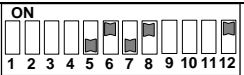

2	=	Link	Local	Scope
5	=	Site	Local	Scope
8	=	Organization	Local	Scope
14	=	Global	Scope	Scope

For supervision and configuration with MOBA-NMS one of the group addresses (multicast IP addresses) 239.192.54.0 or 239.251.34.0 is used (selection with switch 12).

It is possible to connect an I²C monitor to the cascade. The movement writes periodically time, configuration and status information to the display. Monitoring can help to find network configuration errors.

In contrast to the Unicast mode, the movement receives multicast addressed time and time zone packets from a fixed server group address (multicast IP address). The standard port numbers are 123 (NTP) and 65534 (time zone). The Multicast operating mode signifies only a minimum amount of configuration work for a network administrator. The server group address is selected with the switches 5 to 8. In addition switch 12 allows selection of two different address ranges. The following settings are possible:

Switch:	Group address:	Switch:	Group address:
	239.192.54.1 FF38::EFC0:3601		239.251.34.1 FF38::EFC0:3601
	239.192.54.2 FF38::EFC0:3602		239.251.34.2 FF38::EFC0:3602
	239.192.54.3 FF38::EFC0:3603		239.251.34.3 FF38::EFC0:3603
	239.192.54.4 FF38::EFC0:3604		239.251.34.4 FF38::EFC0:3604
	239.192.54.5 FF38::EFC0:3605		239.251.34.5 FF38::EFC0:3605
	239.192.54.6 FF38::EFC0:3606		239.251.34.6 FF38::EFC0:3606
	239.192.54.7 FF38::EFC0:3607		239.251.34.7 FF38::EFC0:3607
	239.192.54.8 FF38::EFC0:3608		239.251.34.8 FF38::EFC0:3608

	239.192.54.9 FF38::EFC0:3609		239.251.34.9 FF38::EFFB:2209
	239.192.54.10 FF38::EFC0:360A		239.251.34.10 FF38::EFFB:220A
	239.192.54.11 FF38::EFC0:360B		239.251.34.11 FF38::EFFB:220B
	239.192.54.12 FF38::EFC0:360C		239.251.34.12 FF38::EFFB:220C
	239.192.54.13 FF38::EFC0:360D		239.251.34.13 FF38::EFFB:220D
	239.192.54.14 FF38::EFC0:360E		239.251.34.14 FF38::EFFB:220E
	239.192.54.15 FF38::EFC0:360F		239.251.34.15 FF38::EFFB:220F

4.3.3 Slave movement (cascading)

The movement has no network connection. It is synchronized with local time and monitored by a master movement (operating mode Unicast or Multicast). The cascade can help to reduce wiring effort since only one LAN connection for double sided clocks is required. The disadvantage is that the slave movement cannot be addressed directly via a network connection. Monitoring is only possible via master movement.

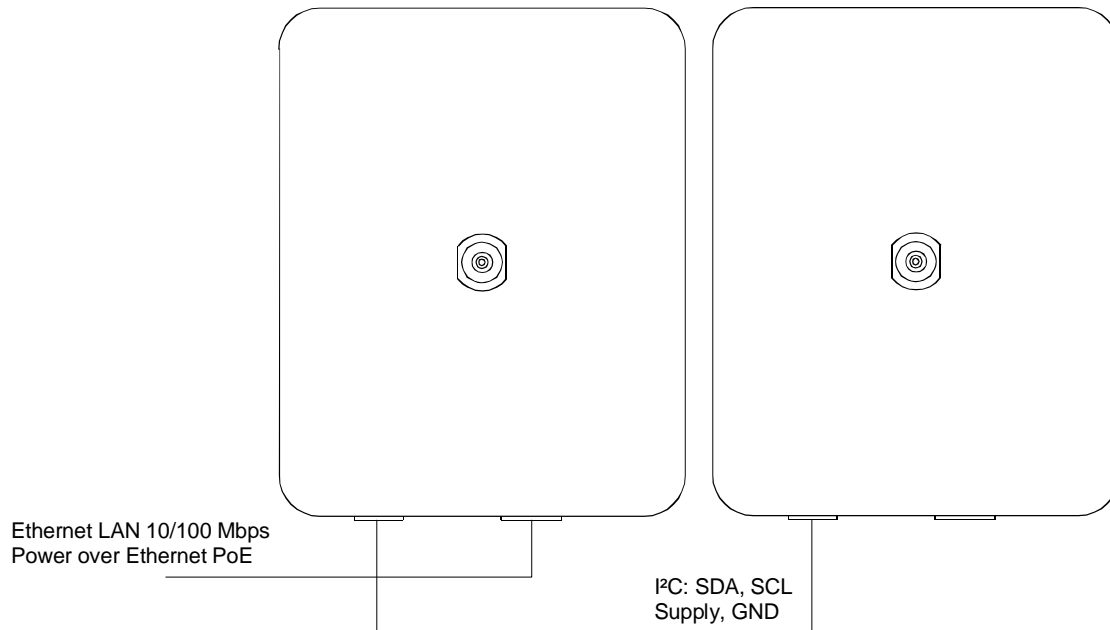

The SEN 40 automatically works as a slave movement when powered by the cascade. If it is powered by PoE, it works as a master movement.



Vorsicht!

The **cascading connection** may only be connected resp. disconnected in a **currentless state** of the master.



Vorsicht!

The slave movements may only be powered from the master movement via the cascading cable. An additional DC power supply is not allowed.

5. Operation details

5.1 Power supply

The movement can be powered by PoE (Power over Ethernet). Either a PoE capable switch or a PoE injector can be used.

The power supply is internally connected to the plug of the I²C cascade. The slave movement is powered by the cascade.

5.2 DHCP

If the movement operates in Unicast mode it automatically tries to obtain the network configuration from a DHCP server within the network. The DHCP options will be evaluated automatically.

The accurate description can be found in the manual BE 800793 Description MOBATime Network clocks.

The network administrator must configure the DHCP options accordingly.

5.3 IPv6

IPv6 allows for up to 4 parallel IP addresses, prioritized in decreasing order:

- address given by DHCPv6
- fix address
- address calculated with auto-config (SLAAC / RA)
- link local address

It is possible to deactivate DHCPv6 and / or auto-configuration.

Calculation of the link local address from the MAC address:

fe80::2[2nd part MAC]:[3rd part MAC]ff:fe[4th part MAC]:[5th part MAC][6th part MAC]

Example: MAC: 00:16:91:12:34:56
 ↓ ↓ ↓ ↓ ↓
 IPV6: fe80::216:91ff:fe12:3456

5.4 DHCPv6

In the unicast operating mode, the SEN 40 tries to get the network configuration from a DHCPv6 server in the IPv6 network. The DHCP options are automatically evaluated.

A detailed description can be found in the manual BE-800793 Description MOBATIME network clocks.

The network administrator is responsible for configuring the DHCP options accordingly.

5.5 Autokonfiguration / SLAAC

In the unicast operating mode, the SEN 40 tries to calculate the network configuration from the information of a router (RA) in the IPv6 network: IPv6 address.

A detailed description can be found in the manual BE-800793 Description MOBATIME network clocks.

5.6 SNMP

The SEN 40 supports SNMP version 2c traps. This allows to integrate the movement to a network management system. The SEN 40 (SNMP agent) can send alarm traps and alive traps to a SNMP manager (e.g. HP OpenView or others). The IP address of the SNMP manager must be provided to the movement by DHCP or MOBA-NMS. The trap structures are defined in a MIB file (refer to document TE-800728 for details). Alarm traps are asynchronous messages and are used to inform the manager about the appearance/disappearance of alarms. Alive traps are sent out periodically to report availability and state of the movement. The interval time can be configured by means of the PC tool MOBA-NMS.

5.7 Local time calculation

NTP movements are synchronized to UTC (Universal Time Coordinated). In order to calculate and display the current local time the movements require additional information. This information is provided by a so called time zone entry (daylight saving time rule). The SEN 40 has a pre-defined table with 7 entries. One of these entries can be selected using the switches 9 to 11 (Note: Switch 4 must be switched off to use the pre-defined table. See chapter 4.2). The pre-defined table can be edited via network with the PC tool MOBA-NMS.

The SEN 40 alternatively supports the calculation of local time based on the time zone entry provided by time zone server (switch 4 set to ON position). If the movement is operating in

Unicast mode it will request the entry from the configured NTP server. If it is operating in Multicast mode it will receive the corresponding entry from the configured server group address (see chapter 4.3.2).

Cascaded slave movements receive local time from the master movement. The switch settings are ineffective.

5.8 Accuracy / synchronization loss

In synchronized state the deviation typically is lower +/-50 ms.

Synchronization loss is signaled after 24 hours by setting the hands to 12:00 position and waiting for renewed synchronization. The deviation without synchronization after 24 h is typically lower +/-2 s (quartz accuracy: 20 ppm at room temperatures). The slave movement totally continues running for 48 hours without synchronization (timeout master + timeout slave).

Note: The mentioned deviations depend on the accuracy and ability of the time source (NTP server). NTP reception can be affected by network traffic and network devices (hubs, switches, routers, firewalls, etc.).

5.9 Time source redundancy

The availability of the time source in the network can be enhanced by redundant installation of NTP servers. Depending on the selected operation mode of the SEN 40 one of the following strategies is recommended (also adequate for time zone servers):

5.9.1 Unicast

Up to four different NTP server addresses can be provided to the SEN 40 by means of DHCP/DHCPv6 or the PC tool MOBA-NMS. If three NTP requests stay unanswered by the current NTP server the movement changes to the next server (if available). The duration until a change happens is depending on the configured NTP request time interval (default: 3 x 10 seconds). After a reset the movement sends the NTP requests to the first server.

5.9.2 Multicast

Two NTP servers have to be installed sending out NTP packets on the same multicast address. The sending intervals of the servers have to be chosen in a ratio that synchronization in normal operation is done by the first server. Only in case of failure of the primary server the secondary server should take over synchronization. The ratio of the number of transmitted packets between primary and secondary server should be about 4:1:

- Sending interval primary server: 1 packet / 1 minute
- Sending interval secondary server: 1 packet / 4 minutes

The selection of the server hence depends on the dominance of the server with the shorter sending interval. If the primary server fails the secondary server thus becomes dominating.

5.10 MOBA-NMS (MOBATime Network Management System)

MOBA-NMS is a Java based PC program used for the configuration and status requests of NTP movements. This software allows for a central configuration of one or multiple devices.

Further informations, manuals and the software itself are available on our website <http://www.mobatime.com>. These are also available on a USB stick (must be ordered separately).

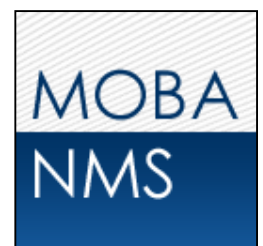

6. Update

The firmware resp. the bootloader of a clock can be updated using MOBA-NMS. However, depending on the reason for change the settings on the clock are lost. The protocol TFTP UDP Port 69 is used.

In the multicast operating mode, an update is carried out sequentially on multiple clocks. In the unicast operating mode, this is done parallel.



Attention: For the update, a DHCP server in the network is required.

The update window is opened by right-clicking on the device → Commands → Firmware Update...:

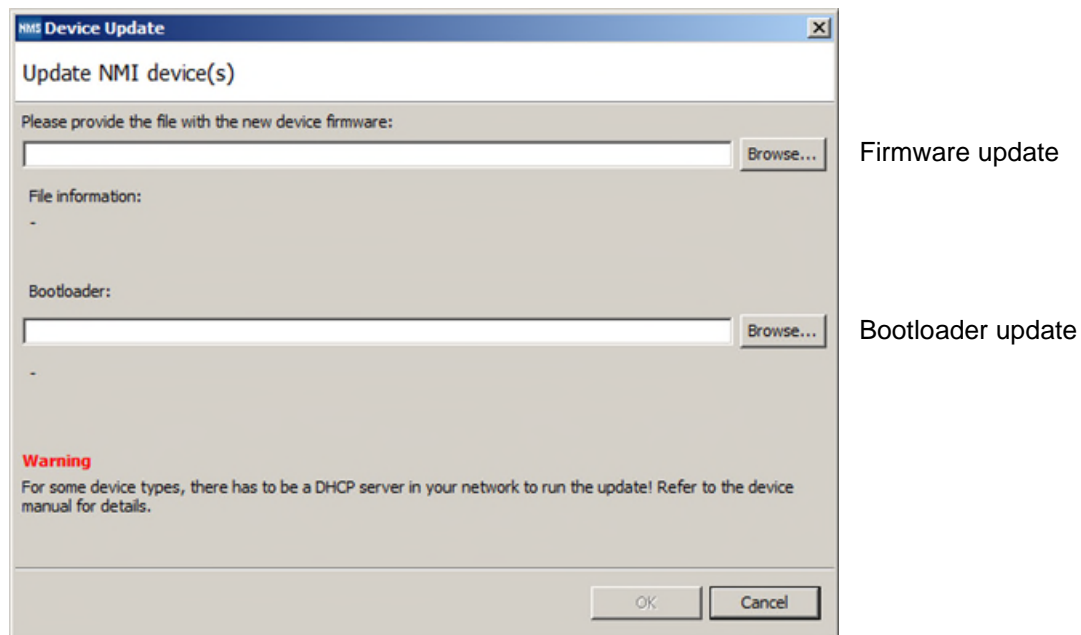

Attention: The newest versions of the firmware and bootloader are available at www.mobatime.com → Customer Area → Product Resources in the respective product folder. If the delivered device contains newer software than displayed in this manual, please check the settings.

6.1 Bootloader update

A bootloader update is only necessary if the respective alarm is displayed:

The image shows two overlapping windows from a management interface. The left window, titled 'Properties', displays the status of an NMI (PM') device. It shows a gauge with a red needle pointing to the 'Alarm' position. The status is 'Alarm' and the alarm(s) is 'Bootloader'. Below this, it lists device information for the last connection, including Type (NMI), Location/Description (PM'), IP address (10.241.0.151), Config. address (10.241.0.151), Port (65532), MAC address (00:16:91:01:08:A0), and Host name (MOBATIME0108A0). It also shows the last status refresh time (Jul 13, 2015 3:01:53 PM) and the next auto refresh interval (2 min, 55 sec). A button labeled 'Open Configuration' is visible.

The right window, titled 'NMI (PM)', provides detailed configuration for the device. It is divided into several sections: 'Device Information' (Type: NMI, Location/Desc.: PM', Date: Jul 13, 2015, Status: Alarm, Run Mode: NTP Client Unicast, Time: 3:05:20 PM, Position: Normal, Output line mode: MOBALine, TZ Source: Local, Alarm(s): Bootloader, Second hand mode: Continuous with stop, TZ Entry: 2, Software: 204880.02.00, Minute hand mode: Stepwise, Last NTP time from: fd03:4432:4646:3454:0:0:0:2000), 'Device Information Network' (MAC Address: 00:16:91:01:08:A0, DHCP: On, Auto conf: On, Multicast Address, IP Address: 10.241.0.151, Auto conf address: fd03:4432:4646:3454:216:91ff:fe01:8a0, Config. IP/Port: 10.241.0.151:65532, Subnet Mask: 255.240.0.0, DHCP V6: On, DNS Server, Gateway: 10.240.2.1, DHCPv6 address: fd03:4432:4646:3454:0:0:0:4ac2, Host name: MOBATIME0108A0, IPv6 link local: fe80:0:0:0:216:91ff:fe01:8a0, IP-Mode: IPv4 & IPv6, IPv6 address / Prefix: 0:0:0:0:0:0:0:0, IPv6 Gateway: fe80:0:0:0:20c:29ff:fec0:8345), and 'MOBALine docks status' (a grid of 12 clock IDs, all marked as 'Not configured'). At the bottom, it shows 'Next refresh: 2 min. 46 sec.' and a 'Refresh' button. Navigation tabs at the bottom include Overview, General Settings, NMI Settings, and Time Zone Settings.

In case of a bootloader alarm, the selection field for the firmware (application) is deactivated and only made available after a successful bootloader update:

The image shows a dialog box titled 'NMS Device Update'. It contains a text field for 'Update NMI device(s)'. Below this, there is a section 'Please provide the file with the new device firmware:' with an empty text field and a 'Browse...' button. Underneath, there is a 'File information:' section with a dash '-' and a 'Bootloader:' section with an empty text field and a 'Browse...' button. At the bottom, there is a 'Warning' section with the text: 'For some device types, there has to be a DHCP server in your network to run the update! Refer to the device manual for details.' and 'OK' and 'Cancel' buttons.



Important: The bootloader file must be a .zip file.

7. Connectors

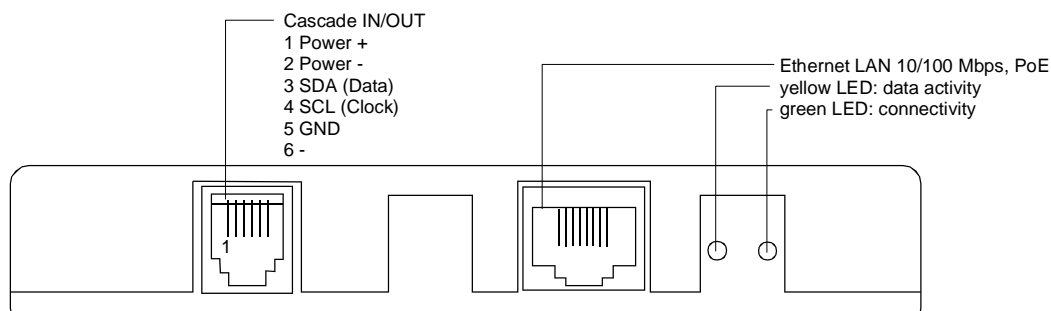

8. Technical specifications

	SAN 40	SEN 40
Network interface	10/100 Mbit/s Ethernet controller, RJ45 plug Only shielded cable permitted	
Network	IPv4 and / or IPv6 with: IPv4: static or DHCP IPv6: static, SLAAC and / or DHCPv6	
Synchronization	Network Time Protocol (NTP), UTC	
Supervision	State request with PC tool MOBA-NMS SNMPv1 alarm and alive traps for integration to a network management system	
Setting time after restart	< 3 minutes 20 seconds	
Daylight saving time changes	< 15 seconds	
Operation mode second shaft	Continuous or stepwise	
Operation mode minute shaft	Continuous or stepwise	
Operation mode hour shaft	Continuous	
Power supply	PoE, phantom (Tx / Rx) oder pins 4,5, und 7,8 (class 1)	
Calculation of local time and daylight saving time change	Automatic daylight saving time change according to 1 out of 7 pre-defined rules or automatic daylight saving time change according to 1 out of 7 rules provided by a MOBATime time zone server	
Accuracy	Deviation typically < +/-50 ms (synchronized)	
Synchronization loss	Signalization after 24 h by setting the hands to 12:00 position Deviation typically < +/-2 s after 24 h	
Number of motors	1 (hour / min.) clockwise / counterclockwise	2 (hour / min. + sec.) clockwise / counterclockwise
Temperature range	-30 ... +70 °C	
Weight	170 g	185 g
Max. hand weight (well balanced)	hour: 7 g; minute: 18 g; second: 3 g	
Dial diameter	max. 400 mm	
Dial thickness	max. 3 mm	
Nut fixing torque	4.5 Nm +/- 0.2 Nm	
Torque on hour shaft	max. 2.8 mNm	
Torque on minute shaft	max. 1.4 mNm	
Torque on second shaft	max. 2.1 mNm	

9. Time Zone Table

Time zone entries of the standard time zone table (version 10.1).

Time zone	City / State	UTC Off-set	DST Change	Standard → DST	DST → Standard
00	UTC (GMT), Monrovia, Casablanca	0	No		
01	London, Dublin, Edinburgh, Lisbon	0	Yes	Last Sun. Mar. (01:00)	Last Sun. Oct. (02:00)
02	Brussels, Amsterdam, Berlin, Bern, Copenhagen, Madrid, Oslo, Paris, Rome, Stockholm, Vienna, Belgrade, Bratislava, Budapest, Ljubljana, Prague, Sarajevo, Warsaw, Zagreb	+1	Yes	Last Sun. Mar. (02:00)	Last Sun. Oct. (03:00)
03	Athens, Istanbul, Helsinki, Riga, Tallinn, Sofia, Vilnius	+2	Yes	Last Sun. Mar. (03:00)	Last Sun. Oct. (04:00)
04	Bucharest, Romania	+2	Yes	Last Sun. Mar. (03:00)	Last Sun. Oct. (04:00)
05	Pretoria, Harare, Kaliningrad	+2	No		
06	Amman	+2	Yes	Last Thu. Mar. (23:59)	Last Fri. Oct. (01:00)
07	UTC (GMT)	0	No		
08	Kuwait City, Minsk, Moscow, St. Petersburg, Volgograd	+3	No		
09	Praia, Cape Verde	-1	No		
10	UTC (GMT)	0	No		
11	Abu Dhabi, Muscat, Tbilisi, Samara	+4	No		
12	Kabul	+4.5	No		
13	Adamstown (Pitcairn Is.)	-8	No		
14	Tashkent, Islamabad, Karachi, Yekaterinburg	+5	No		
15	Mumbai, Calcutta, Madras, New Delhi, Colombo	+5.5	No		
16	Astana, Thimphu, Dhaka, Novosibirsk	+6	No		
17	Bangkok, Hanoi, Jakarta, Krasnoyarsk	+7	No		
18	Beijing, Chongqing, Hong kong, Singapore, Taipei, Urumqi, Irkutsk	+8	No		
19	Tokyo, Osaka, Sapporo, Seoul, Yakutsk	+9	No		
20	Gambier Island	-9	No		
21	South Australia: Adelaide	+9.5	Yes	1 st Sun. Oct (02:00)	1 st Sun. Apr. (03:00)
22	Northern Territory: Darwin	+9.5	No		
23	Brisbane, Guam, Port Moresby, Magadan, Vladivostok	+10	No		
24	Sydney, Canberra, Melbourne, Tasmania: Hobart	+10	Yes	1 st Sun. Oct. (02:00)	1 st Sun. Apr. (03:00)
25	UTC (GMT)	0	No		
26	UTC (GMT)	0	No		
27	Honiara (Solomon Is.), Noumea (New Caledonia),	+11	No		
28	Auckland, Wellington	+12	Yes	Last Sun. Sep. (02:00)	1 st Sun. Apr. (03:00)

29	Majuro (Marshall Is.), , Anadyr	+12	No		
30	Azores	-1	Yes	Last Sun. Mar. (00:00)	Last Sun. Oct. (01:00)
31	Middle Atlantic	-2	No		
32	Brasilia	-3	Yes	3 rd Sun. Oct. (00:00)	3 rd Sun. Feb. (00:00)
33	Buenos Aires, Santiago	-3	No		
34	Newfoundland, Labrador	-3.5	Yes	2 nd Sun. Mar. (02:00)	1 st Sun. Nov. (02:00)
35	Atlantic Time (Canada)	-4	Yes	2 nd Sun. Mar. (02:00)	1 st Sun. Nov. (02:00)
36	La Paz	-4	No		
37	Bogota, Lima, Quito, Easter Island, Chile	-5	No		
38	New York, Eastern Time (US & Canada)	-5	Yes	2 nd Sun. Mar. (02:00)	1 st Sun. Nov. (02:00)
39	Chicago, Central Time (US & Canada)	-6	Yes	2 nd Sun. Mar. (02:00)	1 st Sun. Nov. (02:00)
40	Tegucigalpa, Honduras	-6	No		
41	Phoenix, Arizona	-7	No		
42	Denver, Mountain Time	-7	Yes	2 nd Sun. Mar. (02:00)	1 st Sun. Nov. (02:00)
43	Los Angeles, Pacific Time	-8	Yes	2 nd Sun. Mar. (02:00)	1 st Sun. Nov. (02:00)
44	Anchorage, Alaska (US)	-9	Yes	2 nd Sun. Mar. (02:00)	1 st Sun. Nov. (02:00)
45	Honolulu, Hawaii (US)	-10	No		
46	Midway Islands (US)	-11	No		
47	Mexico City, Mexico	-6	Yes	1 st Sun. Apr. (02:00)	Last Sun. Oct. (02:00)
48	Adak (Aleutian Is.)	-10	Yes	2 nd Sun. Mar. (02:00)	1 st Sun. Nov. (02:00)
49	UTC (GMT)	0	No		
50	UTC (GMT)	0	No		
51	UTC (GMT)	0	No		
52	UTC (GMT)	0	No		
53	UTC (GMT)	0	No		
54	Scoresbysund, Greenland	-1	Yes	Last Sun. Mar. (00:00)	Last Sun. Oct. (01:00)
55	Nuuk, Qaanaaq, Greenland	-3	Yes	Last Sat. Mar. (22:00)	Last Sat. Oct. (23:00)
56	Qaanaaq, Greenland (old)	-4	Yes	2 nd Sun. Mar. (02:00)	1 st Sun. Nov. (02:00)
57	Western Australia: Perth	+8	No		
58	Caracas	-4.5	No		
59	CET standard time	+1	No		
60	Santiago, Chile (old)	-4	Yes	2 nd Sun. Oct. (00:00)	2 nd Sun. Mar. (00:00)
61	Chile, Easter Island (old)	-6	Yes	2 nd Sat. Oct. (22:00)	2 nd Sat. Mar. (22:00)
62	Baku	+4	Yes	Last Sun. Mar. (04:00)	Last Sun. Oct. (05:00)
63	UTC (GMT)	0	No		
64	UTC (GMT)	0	No		

In countries where the DST switch date changes annually (e.g. Iran, Israel), the time zone has to be defined manually in the user time zone table (entries 80 – 99).

Legend:

UTC: Universal Time Coordinate, equivalent to GMT
DST: Daylight Saving Time
DST Change: Daylight Saving Time changeover
Standard → DST: Time change from Standard time (Winter time) to Summer time
DST → Standard: Time change from Summer time to Standard time (Winter time)

Example:

2nd last Sun. Mar. (02:00) Switch over on the penultimate Sunday in March at 02.00 hours local time.



Note:

Usually the time zone table is adapted each year. You can download the latest time zone table at our homepage: www.mobatime.com → Downloads → Moba-Software → Time Zone Table. If the delivered device contains a newer version than printed in this manual please check the time zone entries.

10. Accessories

Position:	Descriptive name:	Part number:
1	Central nut M10x1 (2 mm wide, hole 10mm) Central nut M10x1 (4 mm wide, hole 12mm)	20000 203685
2	Rubber washer Ø 40 x 12.5 x 0.5 mm If needed (depending on dial thickness): Rubber washer Ø 40 x 12.5 x 1 mm Rubber washer Ø 43 x 12.5 x 2 mm	32 002 250 079 250 078
3	Metal ring for dial protection (used for nut 203685 only) Ø 16 x 12.5 x 0.5	22699
4	Needles for hand mounting	701710

*Headquarters/Production
Sales Worldwide*

MOSER-BAER AG | Spitalstrasse 7 | CH-3454 Sumiswald
Tel. +41 34 432 46 46 | Fax +41 34 432 46 99
moserbaer@mobatime.com | www.mobatime.com

Sales Switzerland

MOBATIME AG | Stettbachstrasse 5 | CH-8600 Dübendorf
Tel. +41 44 802 75 75 | Fax +41 44 802 75 65
info-d@mobatime.ch | www.mobatime.ch

MOBATIME SA | En Budron H 20 | CH-1052 Le Mont-sur-Lausanne
Tél. +41 21 654 33 50 | Fax +41 21 654 33 69
info-f@mobatime.ch | www.mobatime.ch

Sales Germany/Austria

BÜRK MOBATIME GmbH
Postfach 3760 | D-78026 VS-Schwenningen
Steinkirchring 46 | D-78056 VS-Schwenningen
Tel. +49 7720 8535 0 | Fax +49 7720 8535 11
buerk@buerk-mobatime.de | www.buerk-mobatime.de
